

Product Information

Servo-hydraulic Testing Machine HC10/25 Compact

CTA: 140252 137456



HC Compact

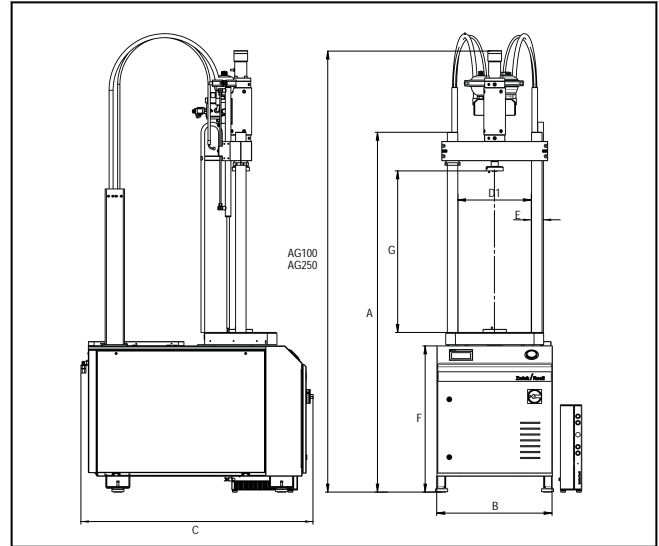

Drawing: HC Compact

Range of application

The HC Compact is a complete and extremely space-saving testing system, as the low-noise power pack forms the base support for the test frame. With a testing actuator mounted in the upper crosshead and a hard-chromed T-slotted platform, the testing machine is suitable for static and dynamic tests of all types up to 25 kN, including flexure tests, tests on components and biomedical tests.

Description of operation

The 2-column load frame is bolted directly to the hydraulic power-pack and is designed so that no additional sound insulation measures of any sort are required, making the HC Compact suitable for installation in almost any laboratory. For maintenance operations the hydraulic power-pack can simply be moved out sideways on guide rails.

The entire testing system, including the hydraulic power-pack, is carried on anti-vibration leveling units. With a total weight of approximately 1,200kg, it can be erected on almost any industrial floor. The load cell can be attached to the table top or the piston rod, depending on the type of test. If standard specimen grips are used, mounting on the fixed lower T-slotted plate is advisable.

The frame also features extremely precise alignment; following installation of the testing actuator and load

cell, alignment accuracy is +0.1 mm per meter separation; at distances below 350mm the offset is constant at 0.05mm. Plane-parallelity of mounting surfaces is equal to or better than 0.03 mm per 100 mm. All fixtures and ZwickRoell load cells are mounted via flanges with centering-spigot. An alignment unit is also optionally available in the product range.

Advantages and features

- Space-saving testing system with integrated hydraulic power-pack.
- Extra-quiet low-noise power pack.
- The entire test, together with set-up and control of automatic extensometers and specimen grips, is run via the display-equipped remote control unit.
- 2-column frame for dynamic tests up to 25kN with testing actuator installed in upper crosshead.
- Suitable for 10 kN and 25 kN axial actuators.
- Hydrostatic-bearing, sealless actuator for virtually frictionless and maintenance-free operation.
- Hard-chromed T-slotted platform and columns for tests in corrosive media.
- Wide range of accessories: temperature chamber, compression platens, specimen grips, flexure test kit etc.
- Optional hydraulic adjustment for easy positioning of upper crosshead.
- Safety housing for compliance with CE Machinery Directive, depending on application.

Product Information

Servo-hydraulic Testing Machine HC10/25 Compact

Technical data

Test area height	Standard	Extended by 250 mm ¹⁾	Extended by 500 mm	
Dynamic nominal force	25	25	25	kN
A - max. height of end of column	2240	2490	2740	mm
A _{G100} – max. height with 100mm testing actuator	2725	2975	3225	mm
A _{G250} – max. height with 250mm testing actuator	3025	3275	3525	mm
B - max. width	720	720	720	mm
C - max. depth	1360	1360	1360	mm
F - height of top edge of lower crosshead	995	995	995	mm
K - total weight ²⁾	1080	1095	1120	kg
C1 – max. depth of test frame	450	450	450	mm
D1 - distance between columns	460	460	460	mm
E – column diameter	65	65	65	mm
G – max. test area height ³⁾	1070	1320	1570	mm
H – max. working test area height ⁴⁾	310 to 1010	560 to 1260	810 to 1510	mm
Frame stiffness at 1000mm crosshead separation	300	300	300	kN/mm
T-slots	as per DIN 650 12H12, spacing 80 mm			
Connection size	Ø 70 mm, 6 x M8 and Ø 115 mm, 4 x M8			
Clamping/ adjustment: manual/manual	1037238	1037462	1037469	
Clamping/ adjustment: manual/hydraulic	1036930	1036931	1037473	

1) Required for use with temperature chamber

2) With oil and 100mm testing actuator, no grips

3) Distance between upper and lower crossheads

4) Distance between piston flange and lower crosshead with piston retracted

Machine testing actuator

Double-rod cylinder with hydrostatic bearings, sealless, system pressure 210 bar, integrated piston transducer

Nominal force [kN]	Piston stroke [mm]	Connection size	Item No.
10	100	Ø 70 mm, 6 x M8	000152
10	250	Ø 70 mm, 6 x M8	935415
25	100	Ø 70 mm, 6 x M8	924829
25	250	Ø 70 mm, 6 x M8	935414
25 ¹⁾	100	Ø 70 mm, 6 x M8	1036928

1) as machine actuator

Hydraulic power-pack – low-noise

Noise level	<58	dB(A)
System pressure	210	bar

All data at ambient temperature.

Subject to change in the course of further development.

Product Information

Servo-hydraulic Testing Machine HC10/25 Compact

Noise level	<58	dB(A)
Nominal output	10.7	l/min
Volume, oil reservoir	160	l
Coolant water req. max.	5	l/min
Coolant water inlet temperature	15 ... 28	°C
Emitted heat	0,8	kW
Electrical supply	400, 3PH/N/PE, 50 Hz ¹⁾	V
Motor power rating	5	kW
Weight with oil	690	kg
Item No.	1036929	

1) Or: 440 V, 3PH/N/PE, 60 Hz

Load cell

Nominal force [kN]	Accuracy Class 1 ¹⁾ (N)	Item No.
10	≥40	924870
25	≥100	924792
25, direct screw attachment	≥100	1036935

1) to ISO 7500-1

Accessories

Description	ArticleNumber
Piston rod anti-rotation lock for HC frames	1047951
Torque support	644085
Grip control for HC Compact	1052233

Safety device

Aluminium profile section construction with Makrolon panels, safety door at front, electrically monitored and interlocked.

Frame height	Standard	Extended by 250 mm	Extended by 500 mm
Safety device, 4-sided	1036932	1036933	1037670
Safety device, 3-sided, in conjunction with a temperature chamber	-	1037672	1037674
Simple safety guard		1036934	